

Article datasheet
Harness Rap

Article-No.: 014.75.150

Manufacturer: SES-Sterling

Manufacturer article-no.: 0819 0022 010

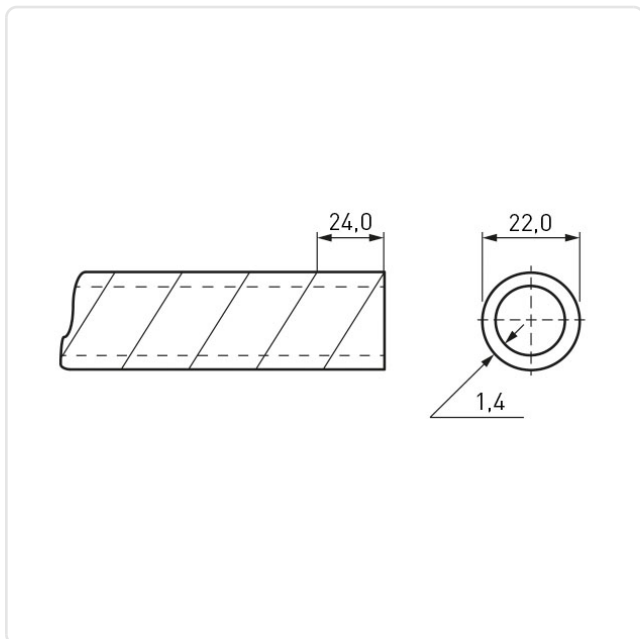

Image may be similar

Bundle Diameter [mm]: 25,0-100,0
Color: Black
Material: PE - Polyethylene
Model: Spiral Cable Wrap
Reel length [m]: 25
Weight: 2268g
Conformities:



You can find all
information on the web on
our article detail page



Would you like individual advice?

We look forward to your email to products@ettinger.de.

Subject to change and errors.