

Article datasheet

Battery Holder 1/2 AA PCB Mounting THM

Article-No.: 015.71.432

Manufacturer: Keystone Electronics

Manufacturer article-no.: 108

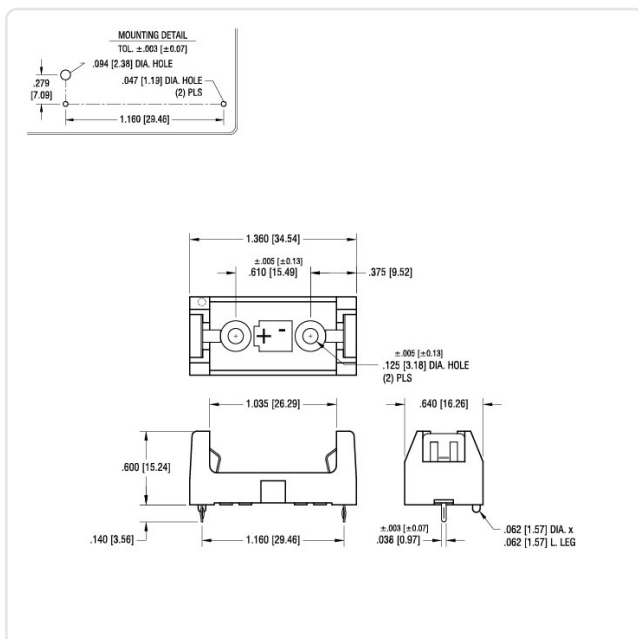

Image may be similar

Battery Type: 1/2 AA-Mignon
 Flammability Class: UL94-V0
 Material: PBT - Polybutylene Terephthalate
 Material Group: Plastic
 Model: PCB Mounting Connection
 No. Cells: 1
 Weight: 7.2g
 Conformities:



You can find all information on the web on our article detail page



Would you like individual advice?

We look forward to your email to products@ettinger.de.

Subject to change and errors.