

Article datasheet

Test Point \varnothing 1.3mm/THM/color green Base Nylon 46 heat resist/silver

Article-No.: 013.08.505

Manufacturer: Keystone Electronics

Manufacturer article-no.: 5116

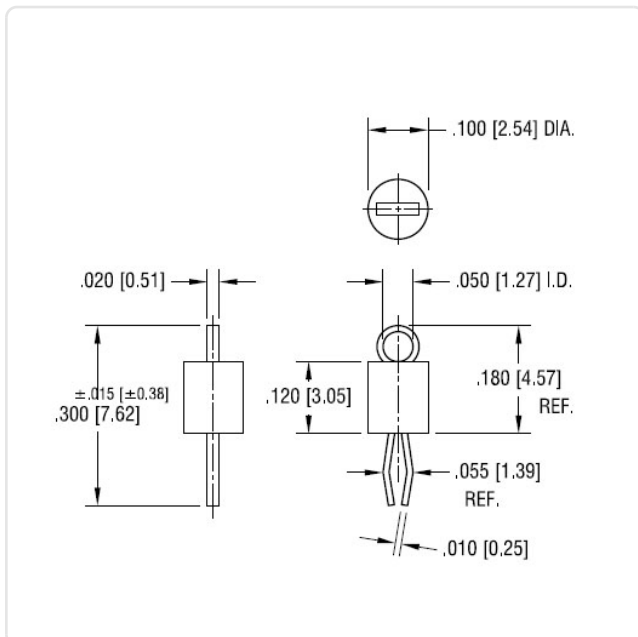

Image may be similar

Diameter [mm]: 2.5
 Finish: Silver-Plated
 Grid [mm]: 3.05
 Length [mm]: 7.6
 Material: Plastic
 Material Group: Plastic
 PCB Hole \varnothing [mm]: 1
 Weight: 0.07g
 Conformities:



You can find all information on the web on our article detail page



Would you like individual advice?

We look forward to your email to products@ettinger.de.

Subject to change and errors.