

Article datasheet

Harness Wrap 5-20, PE, natural, Roll of 25m

Article-No.: 014.75.121

Manufacturer: SES-Sterling

Manufacturer article-no.: 0819 0002 018



Image may be similar

Bundle Diameter [mm]: 5,0-20,0

Color: Natural

Material: PE - Polyethylene

Model: Spiral Cable Wrap

Reel length [m]: 25

Weight: 316g

Conformities:



You can find all
information on the web on
our article detail page

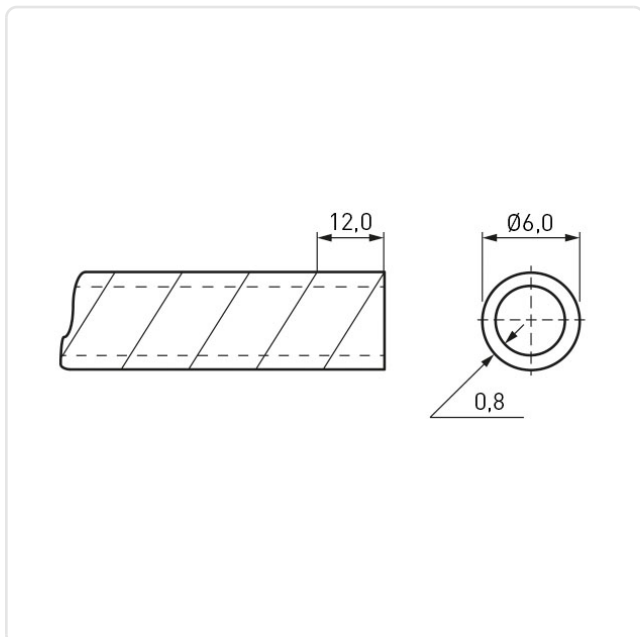

Would you like individual advice?

We look forward to your email to products@ettinger.de.

Subject to change and errors.