

Article datasheet

Harness Wrap 1.5-7.0, PA, natural, 50m-roll

Article-No.: 014.75.111

Manufacturer: SES-Sterling

Manufacturer article-no.: 0819 0001 018

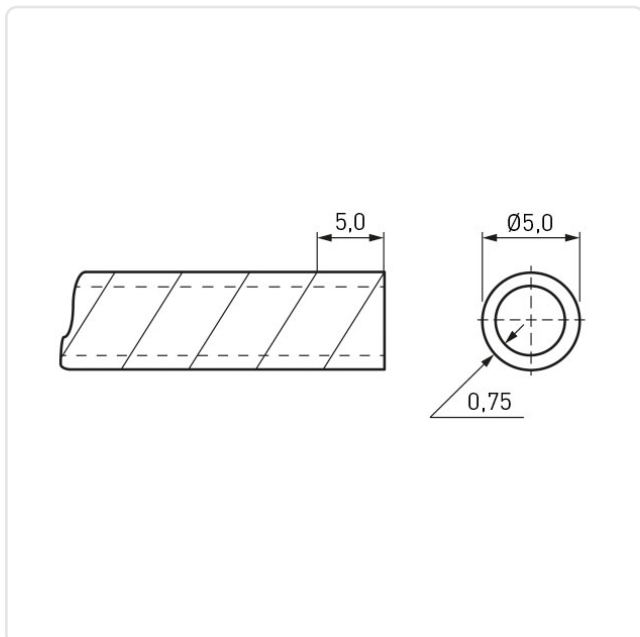

Image may be similar

Bundle Diameter [mm]: 1,5-7,0
Color: Natural
Material: PE - Polyethylene
Model: Spiral Cable Wrap
Reel length [m]: 50
Weight: 226g
Conformities:



You can find all information on the web on our article detail page



Would you like individual advice?

We look forward to your email to products@ettinger.de.

Subject to change and errors.