

Article datasheet

## Diecast Aluminum Enclosures 1590 / IP 54 / 38.5 x 27 x 92.5 mm

Article-No.: 097.05.091

Manufacturer: Hammond

Manufacturer article-no.: 1590A

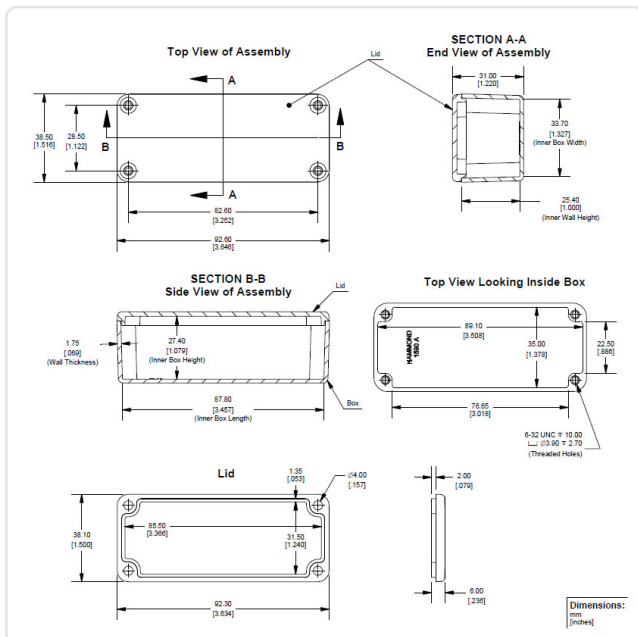

Image may be similar

Height [mm]: 27  
 Length [mm]: 92.5  
 Material: Aluminum  
 Material Group: Aluminum  
 Protection Code: IP54  
 Width [mm]: 38.5  
 Weight: 80g  
 Conformities:



You can find all information on the web on our article detail page



Would you like individual advice?

We look forward to your email to [products@ettinger.de](mailto:products@ettinger.de).

Subject to change and errors.