

Article datasheet

## SMD Mini-Auto Blade Fuse Clip for .110x.032 Blade Fuses/30A max.

Article-No.: 015.06.096

Manufacturer: Keystone Electronics

Manufacturer article-no.: 3563

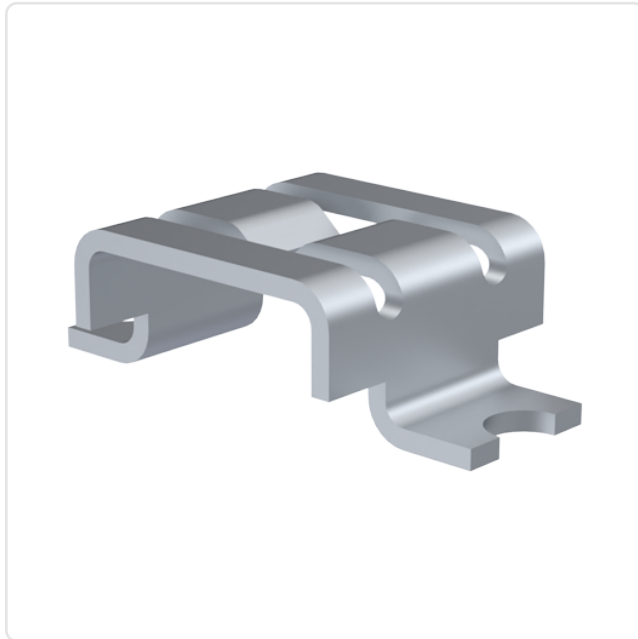
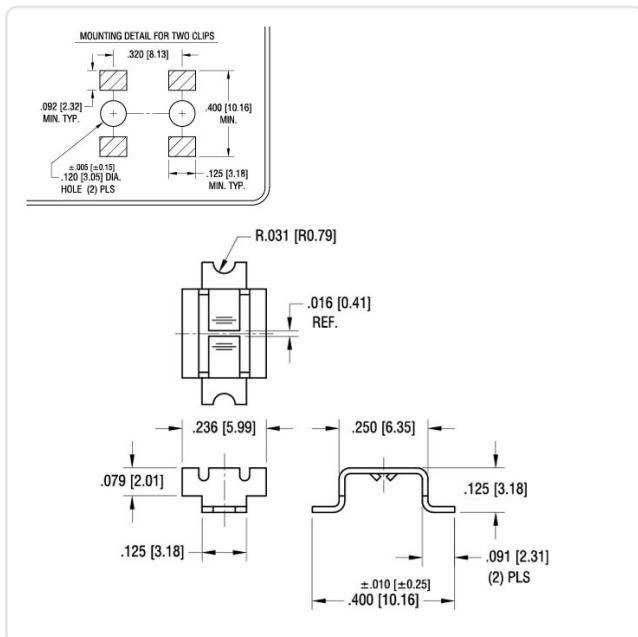

Image may be similar

Amperage [A]: 30  
 Finish: Tin-Plated  
 Fuse Size [mm]: 2.8x0.8  
 Material: Brass  
 Model: Clip Holder  
 Weight: 0.22g  
 Conformities:



You can find all information on the web on our article detail page



Would you like individual advice?

We look forward to your email to [products@ettinger.de](mailto:products@ettinger.de).

Subject to change and errors.