

Article datasheet

Diecast Aluminum Enclosure 1590FL / IP65 / unpainted / Flanged Lid

Article-No.: 097.06.059

Manufacturer: Hammond

Manufacturer article-no.: 1590WTFL

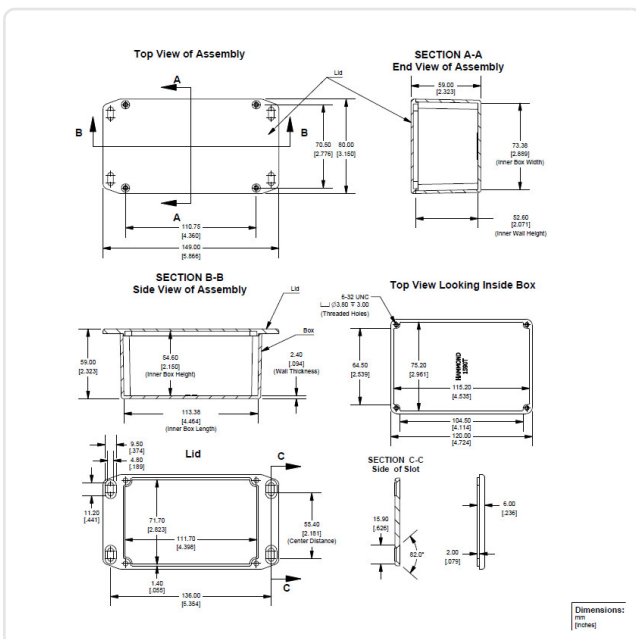

Image may be similar

Height [mm]: 55
 Length [mm]: 120.5
 Material: Aluminum
 Protection Code: IP65
 Width [mm]: 79.5
 Weight: 314g
 Conformities:



You can find all information on the web on our article detail page



Would you like individual advice?

We look forward to your email to products@ettinger.de.

Subject to change and errors.