

Article datasheet

Coincell Holder for $\varnothing 20 \times 3 \text{mm}$ cells PBT black UL94-V0 E45587

Article-No.: 015.61.200

Manufacturer: Keystone Electronics

Manufacturer article-no.: 101

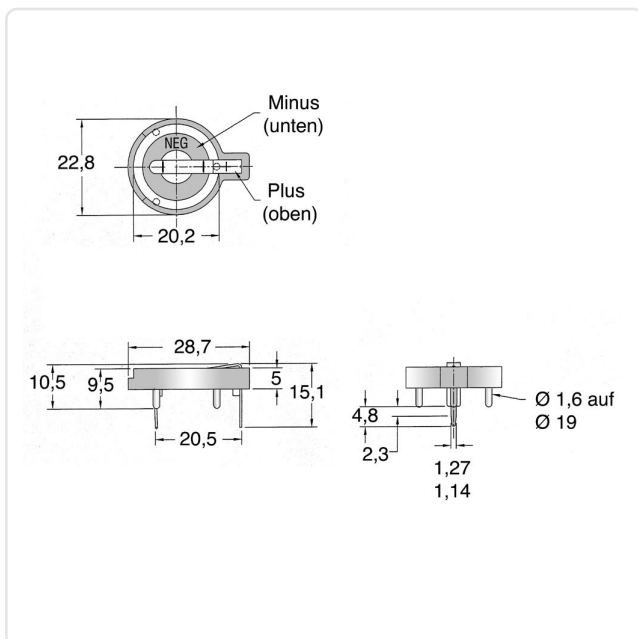

Image may be similar

Battery Type: Cell Dia. 20mm
 Cell diameter [mm]: $\varnothing 20.0$
 Finish: Tin-Plated
 Flammability Class: UL94-V0
 Height [mm]: 9.5
 Material: PBT - Polybutylene Terephthalate
 Material Group: Plastic
 Model: PCB Mounting Connection
 No. Cells: 1
 Weight: 2.55g
 Conformities:



You can find all information on the web on our article detail page



Would you like individual advice?

We look forward to your email to products@ettinger.de.

Subject to change and errors.