

Article datasheet

Coincell Holder for 1x \varnothing 16mm cell LCP Glass Filled UL94-V0

Article-No.: 015.61.161

Manufacturer: Keystone Electronics

Manufacturer article-no.: 502

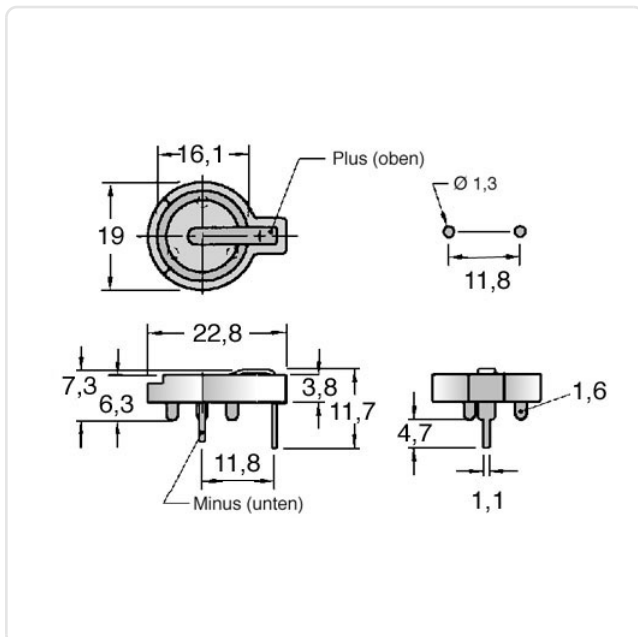

Image may be similar

Battery Type: Cell Dia. 16mm
Cell diameter [mm]: \varnothing 16.0
Finish: Nickel-Plated, 3 μ m, E1E
Flammability Class: UL94-V0
Material: PBT - Polybutylene Terephthalate
Model: PCB Mounting Connection
No. Cells: 1
Weight: 1.16g
Conformities:



You can find all information on the web on our article detail page



Would you like individual advice?

We look forward to your email to products@ettinger.de.

Subject to change and errors.