

Article datasheet

## Battery Clip for 9V cell Steel nickel-plated hole $\varnothing 2.5\text{mm}$

Article-No.: 015.89.333

Manufacturer: Keystone Electronics

Manufacturer article-no.: 80

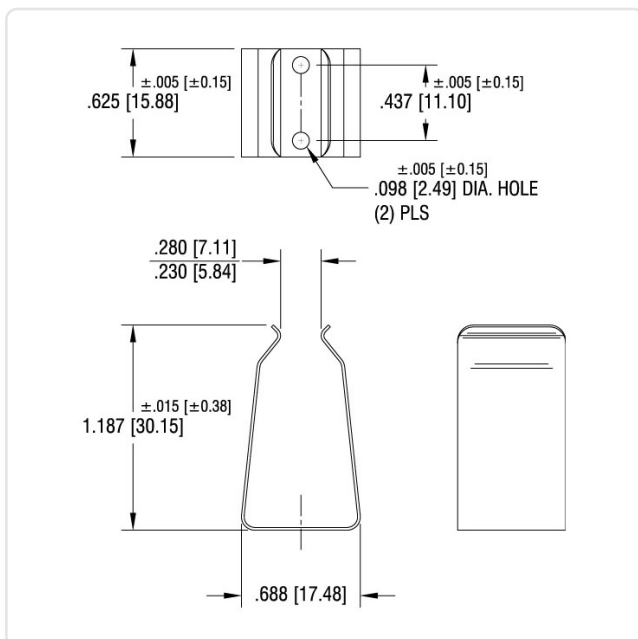

Image may be similar

Battery Type: 9V-Block  
 Finish: Nickel-Plated, 3  $\mu\text{m}$ , E1E  
 Material: Steel  
 Material Group: Steel  
 Width [mm]: 15.9  
 Weight: 4g  
 Conformities:



You can find all information on the web on our article detail page



Would you like individual advice?

We look forward to your email to [products@ettinger.de](mailto:products@ettinger.de).

Subject to change and errors.