

Article datasheet

## Push-In Foot Ø12.0x3.0 PVC black

Article-No.: 017.55.120

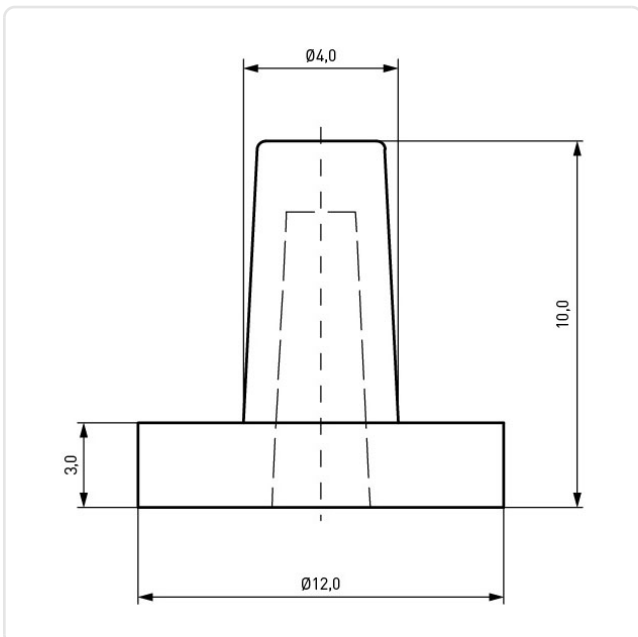

Image may be similar

Color: Black  
Diameter [mm]: 12  
Height [mm]: 3  
Material: PVC - Polyvinyl Chloride  
Panel Hole Ø [mm]: 8  
Weight: 0.47g  
Conformities:



You can find all  
information on the web on  
our article detail page



Would you like individual advice?

We look forward to your email to [products@ettinger.de](mailto:products@ettinger.de).

Subject to change and errors.